

# THERMOFOR AUTOMATIC ROOF VENT OPENER

FIG 1

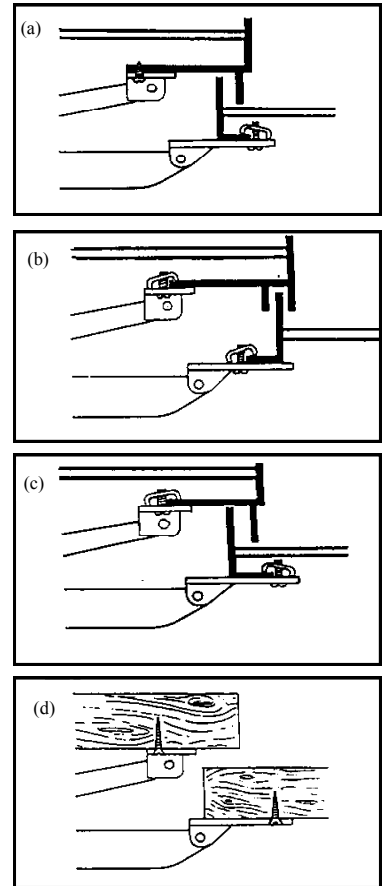
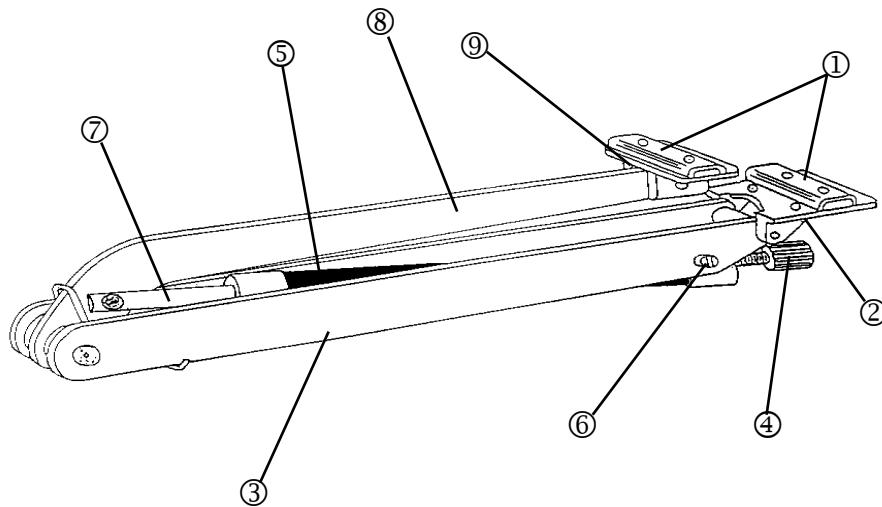

## INSTALLATION/OPERATING INSTRUCTIONS

### PARTS LIST (See Fig. 1)

1. Gripping Channels
2. Gripper
3. Lower Arms
4. Adjusting Screw
5. Cylinder
6. Studs
7. Piston Rod
8. Upper Arm
9. Window Bracket

### BEFORE FITTING

Remove existing window casement stay and fittings from window and frame. Ensure that the greenhouse window opens freely and is not obstructed. If necessary lubricate moving parts with thin oil.

Loosely fit adjusting screw (4) into end of cylinder. DO NOT tighten at this stage. Assemble the cylinder to bracket by feeding the piston rod (7) into the end of the cylinder (5), pushing **firmly** into place, and secure to lower arms (3) by means of threaded studs (6) provided. It may be easier to do this if the arms are slightly open.

Loosely fit the gripping channels (1) to the gripper (2) and window bracket (9) using the screws supplied. Again it may be easier to do this if the arms are opened slightly by turning the adjusting screw (4) clockwise.

### 1) FIT UPPER ARM TO WINDOW

Secure window bracket centrally to window by sliding gripping channel between bottom rail and glass and position screws as close to edge of bottom rail as possible. Tighten screws sufficiently to hold in place.

### 2) FIT LOWER ARMS TO SILL BAR

1. Turn adjusting screw anti-clockwise until the arms close. It may be necessary to allow the cylinder to cool.
2. Attach gripper to sill bar by sliding gripping channel over sill bar and position screws as close to edge of sill bar as possible. Tighten screws sufficiently to hold in place.

3. With the window closed the upper arm (8) should be positioned closely in line with but not touching the glass. To achieve this it may be necessary to re-position the gripping channel in the adjusting slots in the window bracket and/or alter the position of the gripping channel on the gripper by using another set of holes.

4. When adjustments are complete tighten both gripping channels ensuring the upper arm is central to the lower arms.

When fitting to wooden greenhouses the window bracket (9) and the gripper (2) can be screwed directly on to the framework using No. 8 round head wood screws. See fig. (d).

### ADJUSTMENT

After allowing the autovent cylinder to reach the temperature at which you require the window to start opening hold the window slightly open and firmly turn the adjusting screw in the direction of the 'LO' arrow (clockwise) until the unit begins to support the window without assistance. Any rise in greenhouse temperature will now cause the window to open wider. Further adjustment may be necessary in which case repeat the process ensuring the weight of the window is taken off the unit as before.

By turning the adjusting screw in the direction of the 'LO' arrow (clockwise) the window starts opening at a lower temperature. If the adjusting screw is turned in the direction of the 'HI' arrow (anti-clockwise) the window will not open until a higher temperature is reached.

### PLEASE NOTE: ADJUSTMENT IS MADE EASIER IF THE WINDOW IS PUSHED SLIGHTLY OPEN.

As the cylinder is so positioned to also allow it to sense the effects of any chilling air from outside it will automatically react to this and adjust the window accordingly, giving added protection to your plants.

### PLEASE NOTE

- Do not heat to more than 50°C (122°F)
- Do not apply excessive loads by locking or covering window
- Do not attempt to dismantle the cylinder

### TECHNICAL INFORMATION

Opening temperature range adjustable between 15°C and 25°C (59°F and 77°F).

Will lift 7kg, i.e. a window weighing up to 14kg (glass area not exceeding 0.75 sq. m in aluminium frame).

### MAINTENANCE

Lubricate all moving parts after fitting and each subsequent spring and autumn using a light oil. Use grease or petroleum jelly for the piston rod. After long periods of low temperatures and at least once a year take the weight of the window with one hand and move the adjusting screw clockwise three or four turns then move it anti-clockwise to its original position.

### GUARANTEE

Provided the autovent has been correctly fitted in accordance with these instructions it carries a two year guarantee from date of purchase. Should it fail to operate during this period please return either the complete unit or defective part to the address shown on these instructions.